

SMT TERMINATION (AL2O3)

2 GHZ 2 W

R401.110.005

Series :
TERMINATION

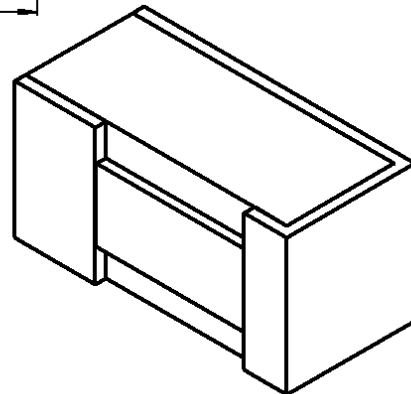
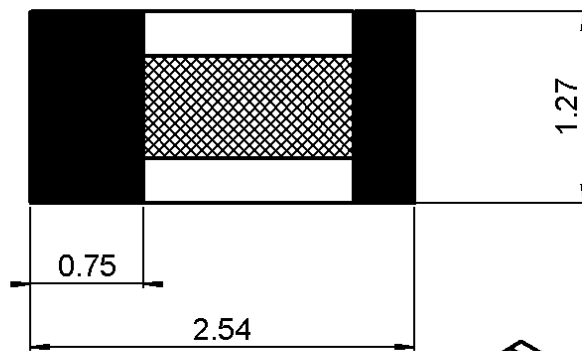

Packaged in a bag of 100 pieces

dimensions are in mm.

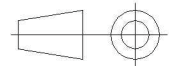

Issue : 0440 A

In the effort to improve our products, we reserve the right to make changes judged to be necessary.



SMT TERMINATION (AL2O3)

2 GHZ 2 W

R401.110.005

Series :
TERMINATION

ELECTRICAL CHARACTERISTICS

Frequency range : DC – 2 GHz
 Impedance : 50 ohms ±5%
 Average Power : 2 W

Frequency	DC – 2 GHz				
V.S.W.R	<= 1.20				

MECHANICAL CHARACTERISTICS

Substrate : Al₂O₃
 Resistive film type : Thick film
 Protective coating : Epoxy
 Solderable terminal & ground : PtAg

OTHER CHARACTERISTICS

Power derating
Versus temperature

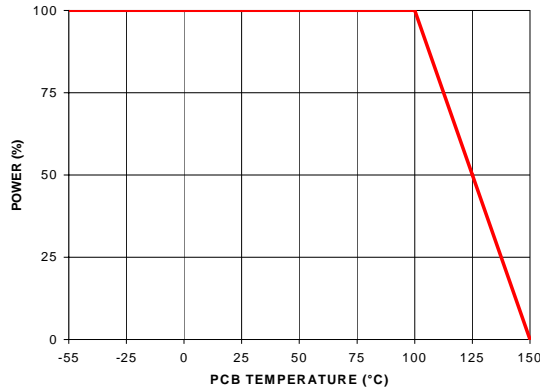

ENVIRONMENTAL

Operating temperature range : -55°C + 150°C

Issue : 0440 A

In the effort to improve our products, we reserve the right to make changes judged to be necessary.

